

**Putzmeister**

# Stationary concrete pump

# BSA 2108 HP E

Output up to 79 m<sup>3</sup>/h  
Delivery pressure up to 220 bar

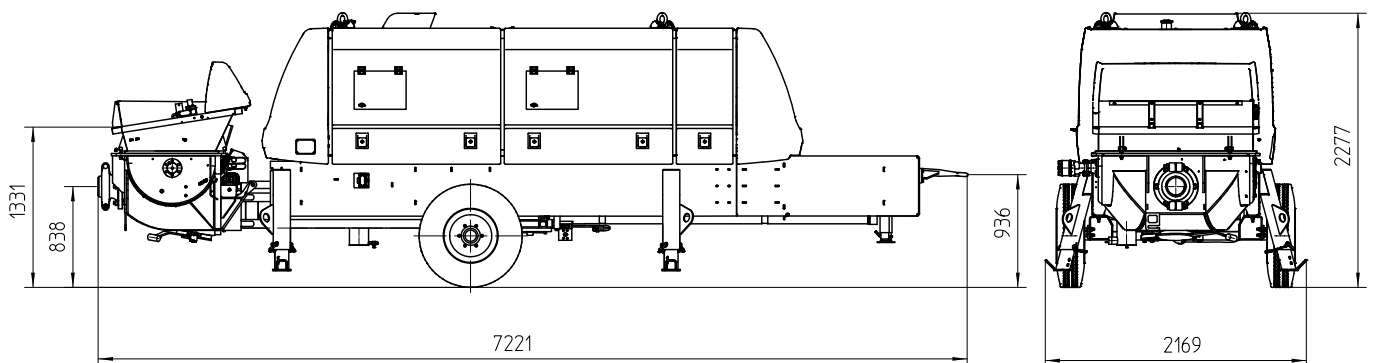

Note: Standard version. Dimensions and weights depend on equipment. Subject to technical modifications and errors.

## Technical data

Type		BSA 2108 HP E
Material number		102438.000
Output	m <sup>3</sup> /h	79 / 55 *
Delivery pressure	bar	150 / 220 *
Delivery cylinder	Ø mm	200
Delivery cyl. stroke	mm	2100
Strokes / minute		20 / 14 *
Engine / motor power	kW	250 **
Hopper		RS 905 HF
Capacity	l	approx. 600
Filling height	m	approx. 1.3
Transfer tube		S 1812 D
line connection	mm	ZX 125
Pressure connection	"	8
Control system		EPS FFH
Weight	kg	8600

\* Values for hydraulic fluid being fed to piston-side

\*\* Electric motor with 200 kW as an option

All data maximum theoretical

## Serial equipment

Agitator safety switch off	Gate valve connection
Cable remote control 10 m	Grill 60 mm
Central lubrication on hopper with hand lever press	Hard metal wear parts
Cleaning accessories	Operating manuals (1× paper, 1× CD-ROM) spare part list
Coloring: Pump, frame, roof, tank and hood anthracite-grey Cover chrome yellow	Outriggers 4× mech.
Concrete hopper with agitator	Pump flow meter
Concrete output adjust	Set-up foot mech.
Concrete pressure adjust	Splash guard
Coupling ring (DIN)	Tool set incl. standard equipment
Drive electric 250 kW	Trailer F8, travelling in site
Electronic error management	
Ergonic Graphic Display (EGD)	
Flushing water pump 160 l/min 25 bar	

See quotation for exact serial delivery scope.  
Comprehensive range of options available on request.